

# CoreLine WT120C Waterproof

## Installation instructions

Instructions de montage

Instrucciones de montaje

Kokoonpano- ja kiinnitysohjeet

Szerelési utasítások

Montageanleitung

Instrues de montagem

Montaj yönergesi

Návod k montáži

Montage instruktio

Monteringsinstruktioner

Οδηγίες εγκατάστασης

инструкция по монтажу

Istruzioni di montaggio

Monteringsvejledning

Instrukcja montazu

Návod k montáži

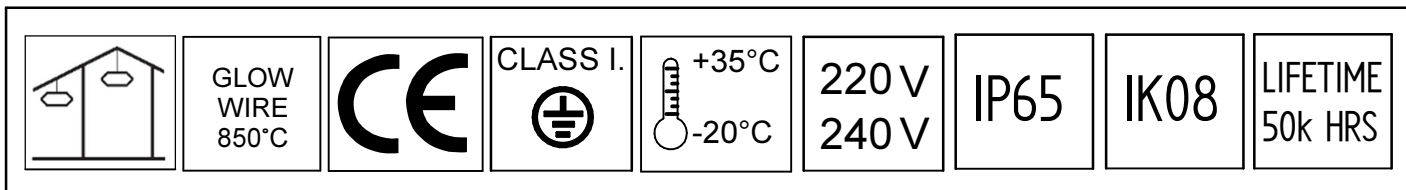

Intended for indoor use,  $t_a=35^{\circ}\text{C}$  MAX or Outdoor-temporary use

Type	Luminous Flux	CCT	Dimension (mm)						P <sub>typ</sub> (W)	kg	Nr. of clips
			A	B	C	D	E	F			
WT120C LED18S/840 PSU L600	1800	4000K	82	661	87	38	388	96	19	0,93	6
WT120C LED22S/840 PSU L1200	2200			1223			960		23		
WT120C LED40S/840 PSU L1200	4000			1504			1213		41	1,53	10
WT120C LED34S/840 PSU L1500	3400								29		
WT120C LED60S/840 PSU L1500	6000								57	1,82	12

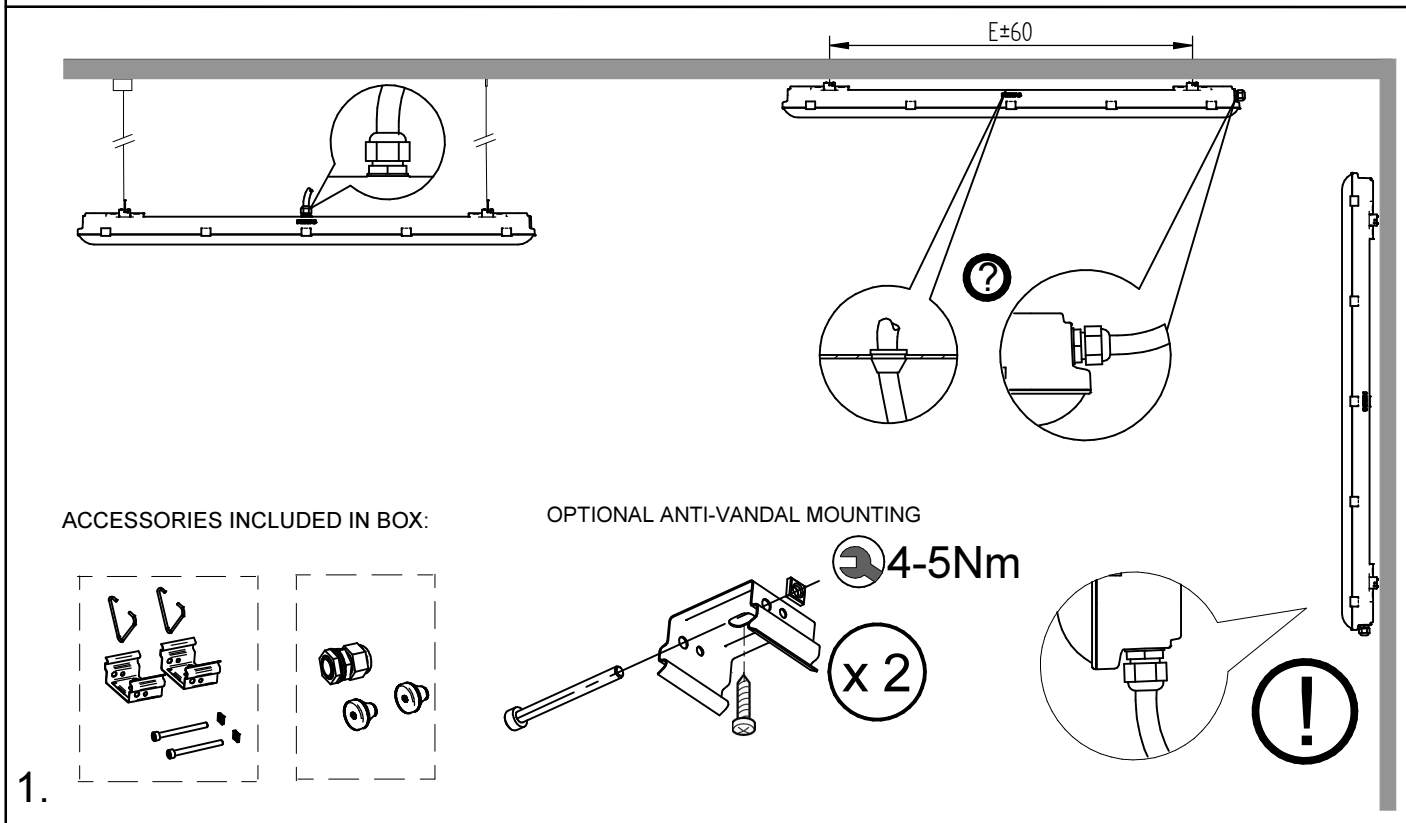
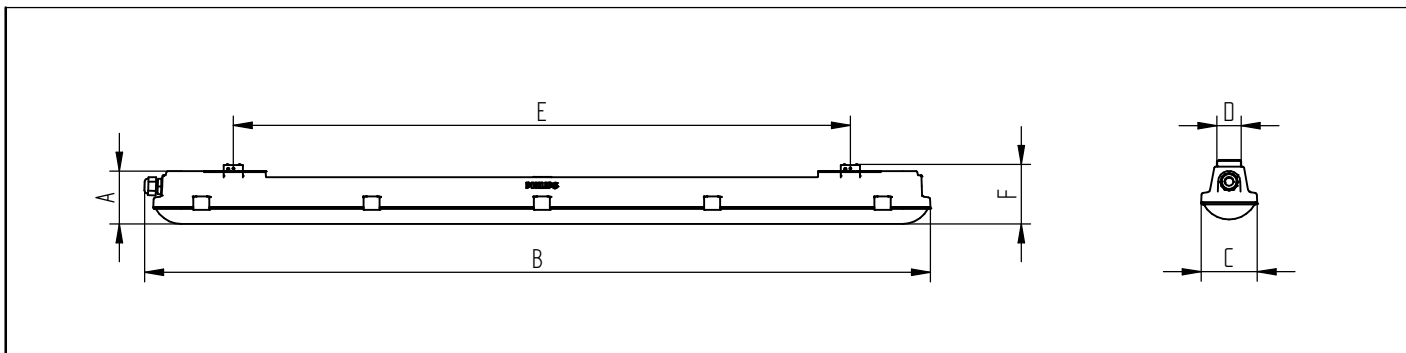

4443 160 02896

Version date 21/03/2014

Data Subject to change without notice

Printed in EU

www.philips.com/lighting

# PHILIPS

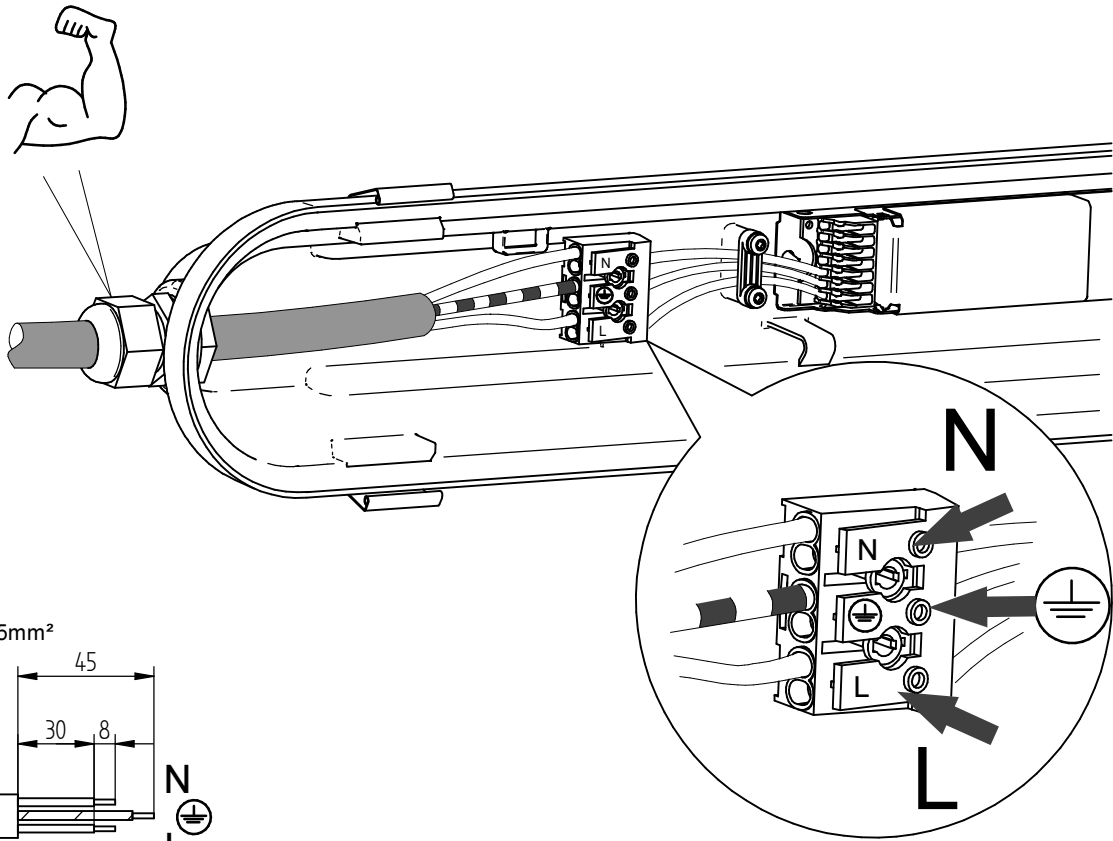

□0,75-2,5mm<sup>2</sup>

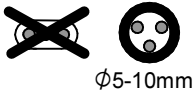
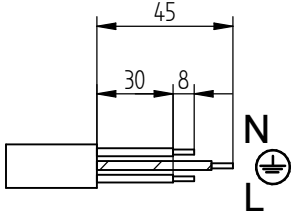

2.

### THROUGH WIRING

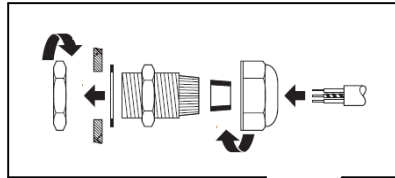
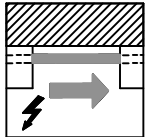

□0,75-2,5mm<sup>2</sup>

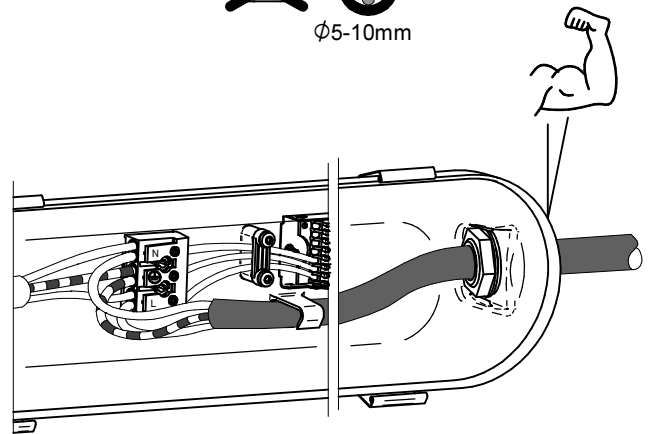
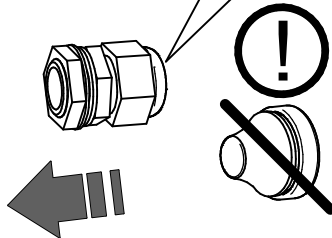
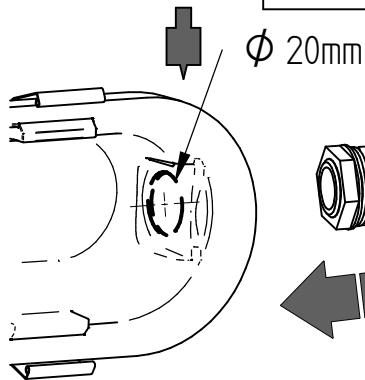
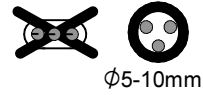
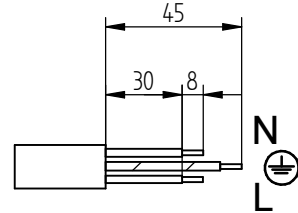

3.

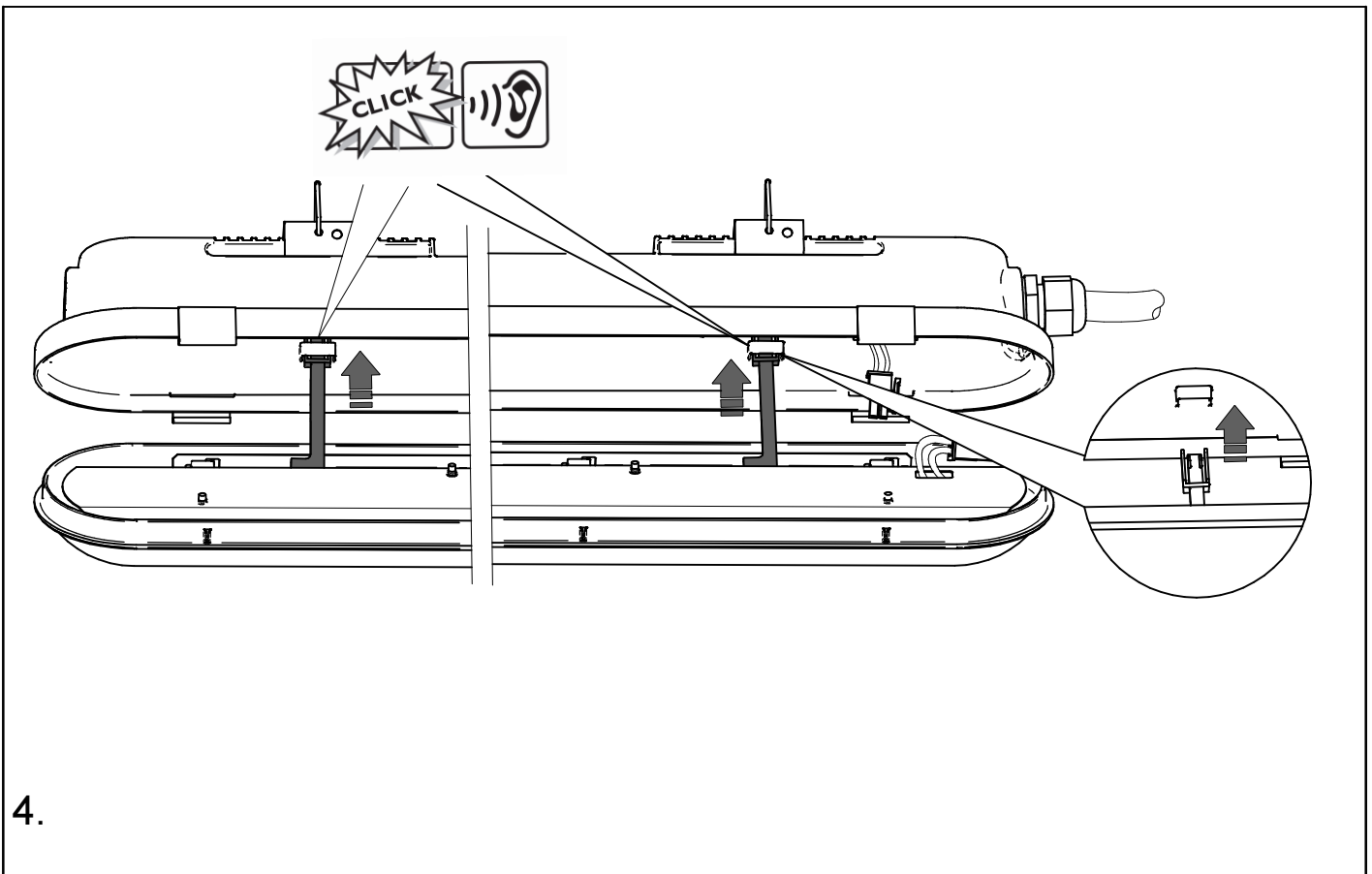

4.

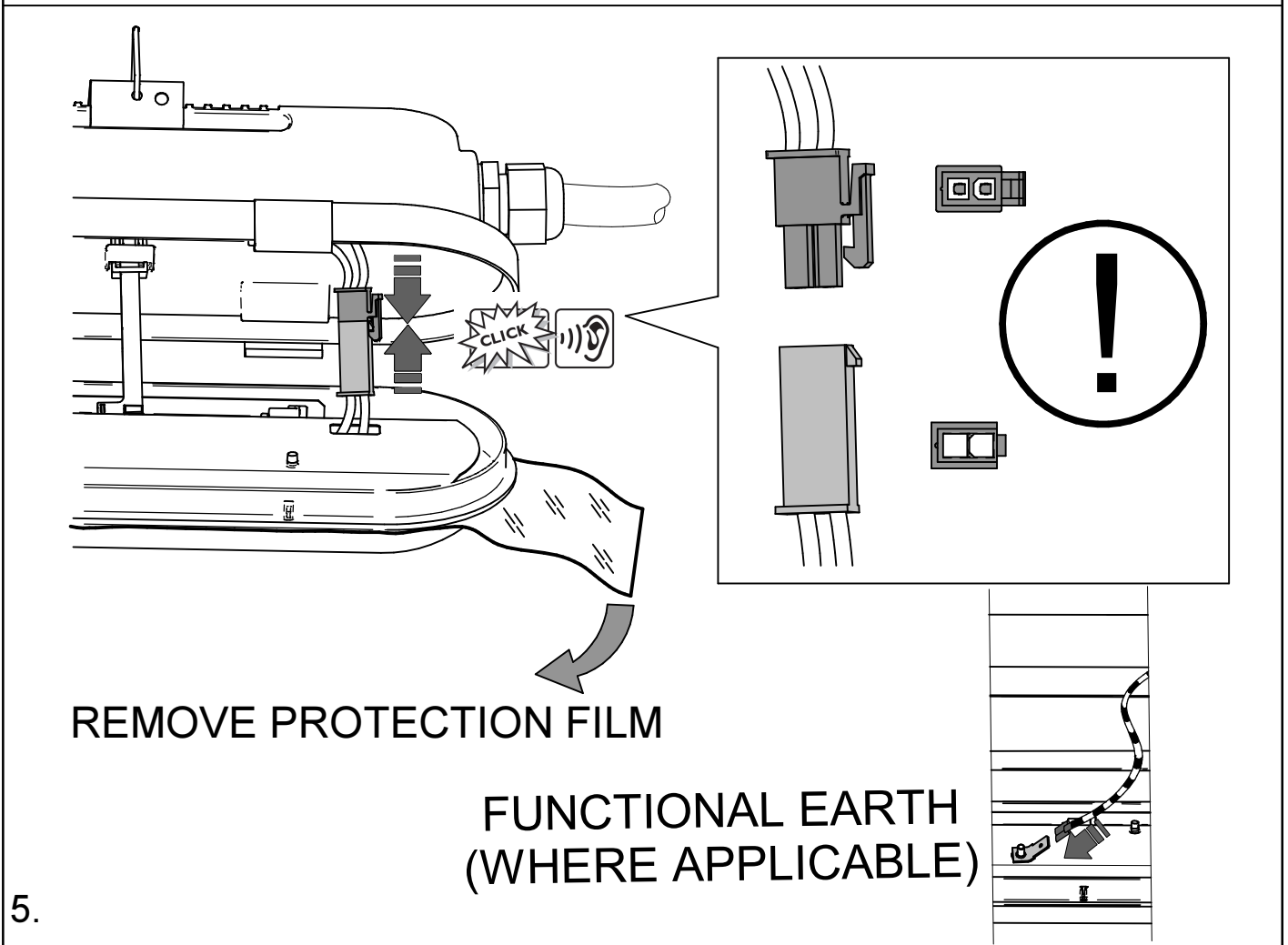

REMOVE PROTECTION FILM

FUNCTIONAL EARTH  
(WHERE APPLICABLE)

5.

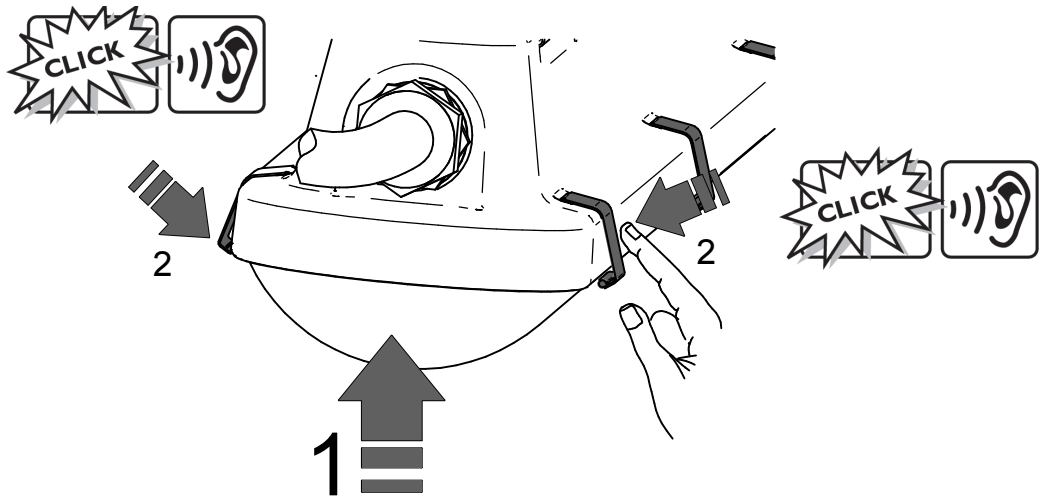

6.

## SERVICE (DRIVER REPLACEMENT)

Light source (LED) is not replaceable.

MAXIMAL SCREWDRIVER SIZE:  
MAX 8mm

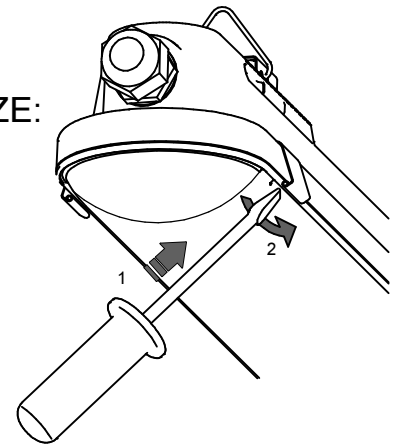

	LED18S	LED22S	LED34S	LED40S	LED60S
I <sub>peak</sub> [A]	21	21	19	22	19
T <sub>width</sub> [μs]	255	255	275	235	275
Max. Nr of products					
Drivers / MCB 16A type B [max.]	24	24	24	24	24
Drivers / MCB 10A type B [max.]	15	15	15	15	15
Drivers / MCB 16A type C [max.]	40	40	40	40	40
Drivers / MCB 10A type C [max.]	24	24	24	24	24

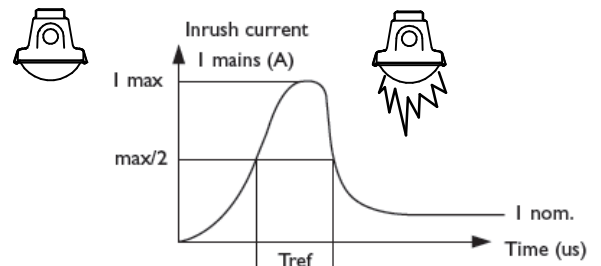

## Maintenance instructions

To assure the lighting quality of this unique LED lighting concept there are only a few instructions regarding the maintenance of this LED luminaire:

- \* Do not touch electronic components!  
Electronic components maybe under high voltage.
- \* Do not stare into LED light beam.
- \* The luminaire shall be installed by a qualified electrician and wired in accordance with the latest IEE electrical regulations or the national requirements.
- \* Above average concentraion of sulfur effects the useful lifetime of the product.  
E.g: Light color changes from white to blue. Typically in chicken & pig farms.

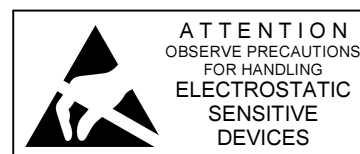

# CoreLine Waterproof WT120C Emergency Light

## Installation instructions

Instructions de montage

Instrucciones de montaje

Kokoonpano- ja kiinnitysohjeet

Szerelési utasítások

Montageanleitung

Instrues de montagem

Montaj yönergesi

Návod k montáži

Montage instruktio

Monteringsinstruktioner

Οδηγίες εγκατάστασης

инструкция по монтажу

Istruzioni di montaggio

Monteringsvejledning

Instrukcja montazu

Návod k montáži

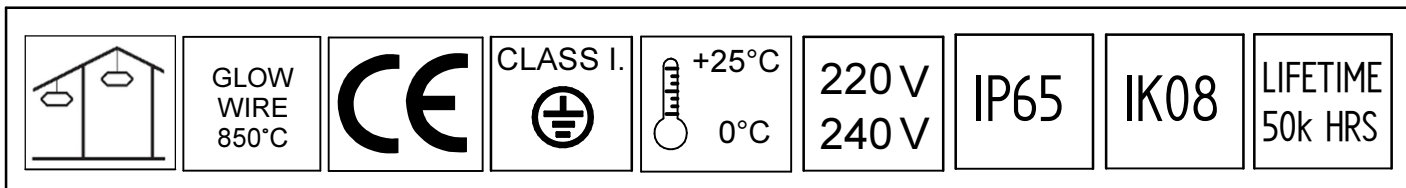

Type	Luminous Flux (lm)		CCT	Dimension (mm)						P <sub>typ</sub> (W)	kg
	standard mode	EL-mode		A	B	C	D	E	F		
WT120C LED22S/840 PSU L1200 EL1	2200	300	4000 K	82	1223	87	38	960	96	23	2,3
WT120C LED22S/840 PSU L1200 EL3											2,5
WT120C LED40S/840 PSU L1200 EL1	4000	300	4000 K	82	1223	87	38	960	96	41	2,3
WT120C LED40S/840 PSU L1200 EL3											2,5
WT120C LED34S/840 PSU L1500 EL1	3400	300	4000 K	82	1504	87	38	1213	96	29	2,5
WT120C LED34S/840 PSU L1500 EL3											2,7
WT120C LED60S/840 PSU L1500 EL1	6000	300	4000 K	82	1504	87	38	1213	96	57	2,5
WT120C LED60S/840 PSU L1500 EL3											2,7

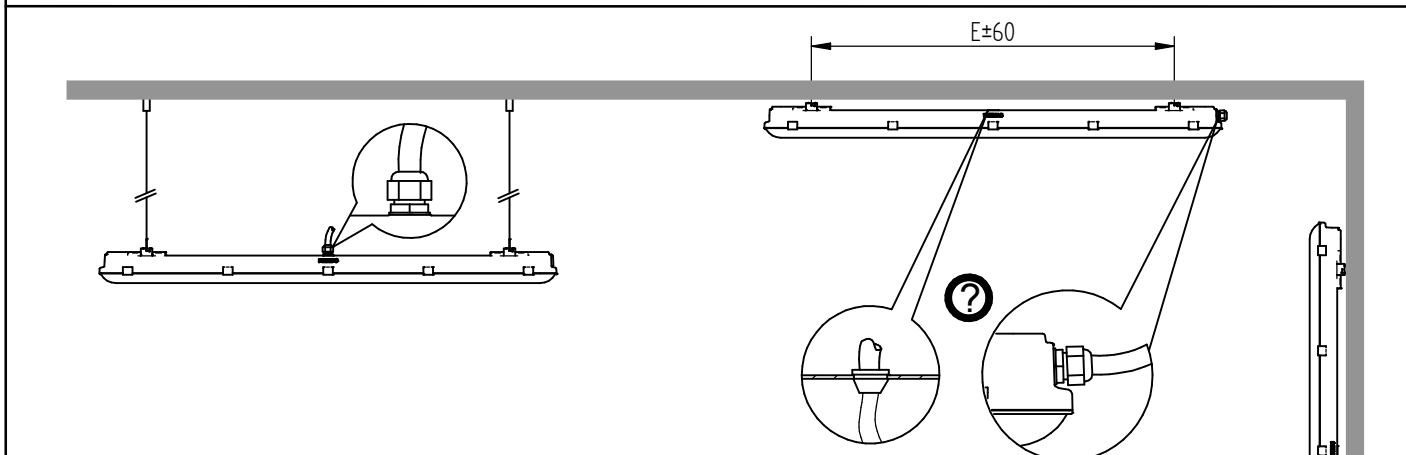
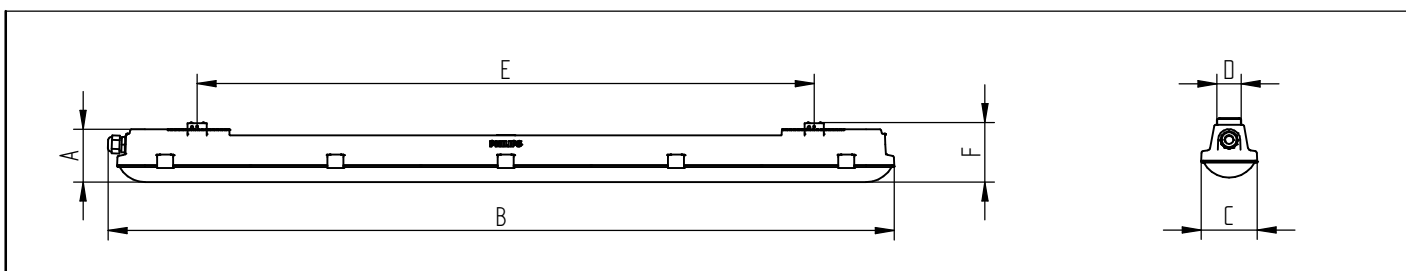

ACCESSORIES INCLUDED IN BOX:

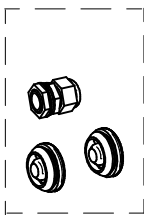
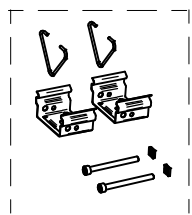

OPTIONAL ANTI-VANDAL MOUNTING

4-5Nm

x 2

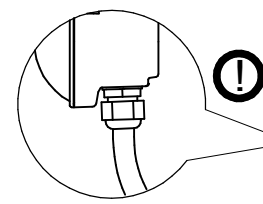

1.

4443 160 03843

Version date : 31/01/2014

Data Subject to change without notice

Printed in EU

www.philips.com/lighting

**PHILIPS**

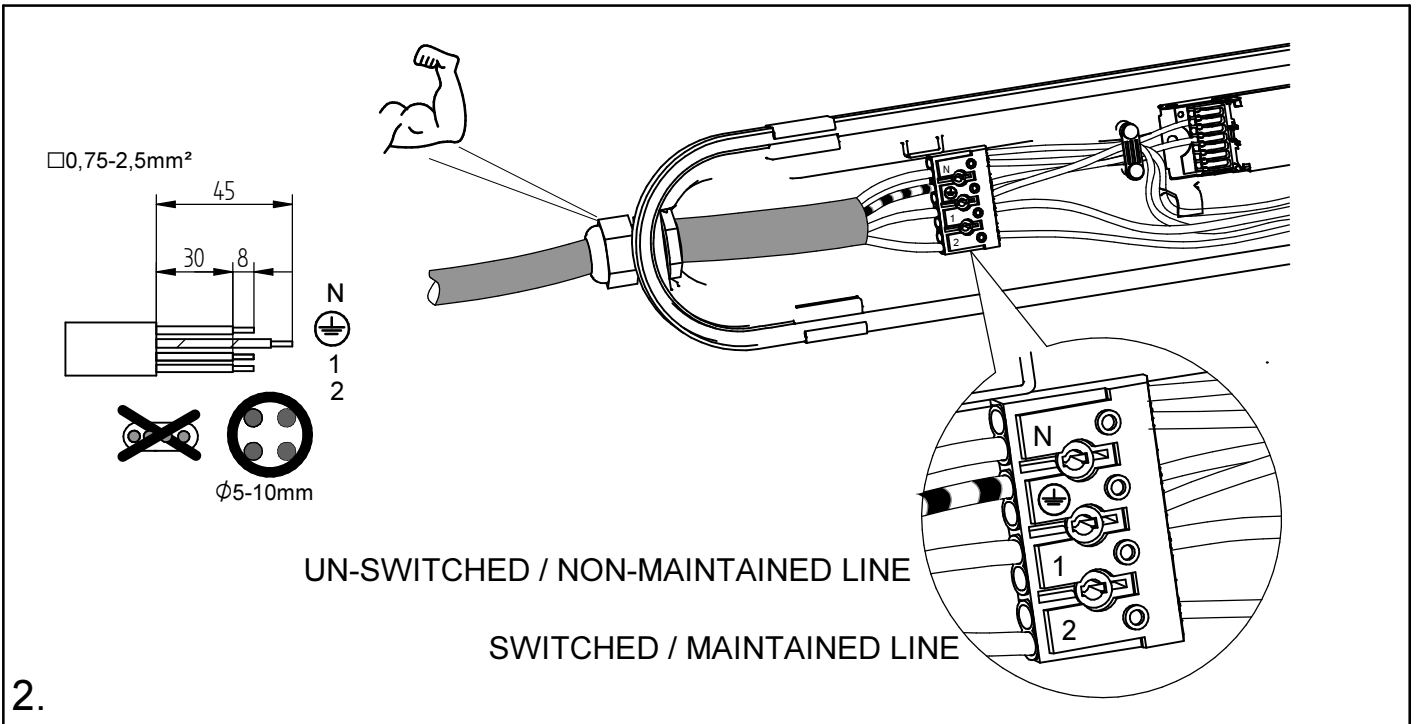

2.

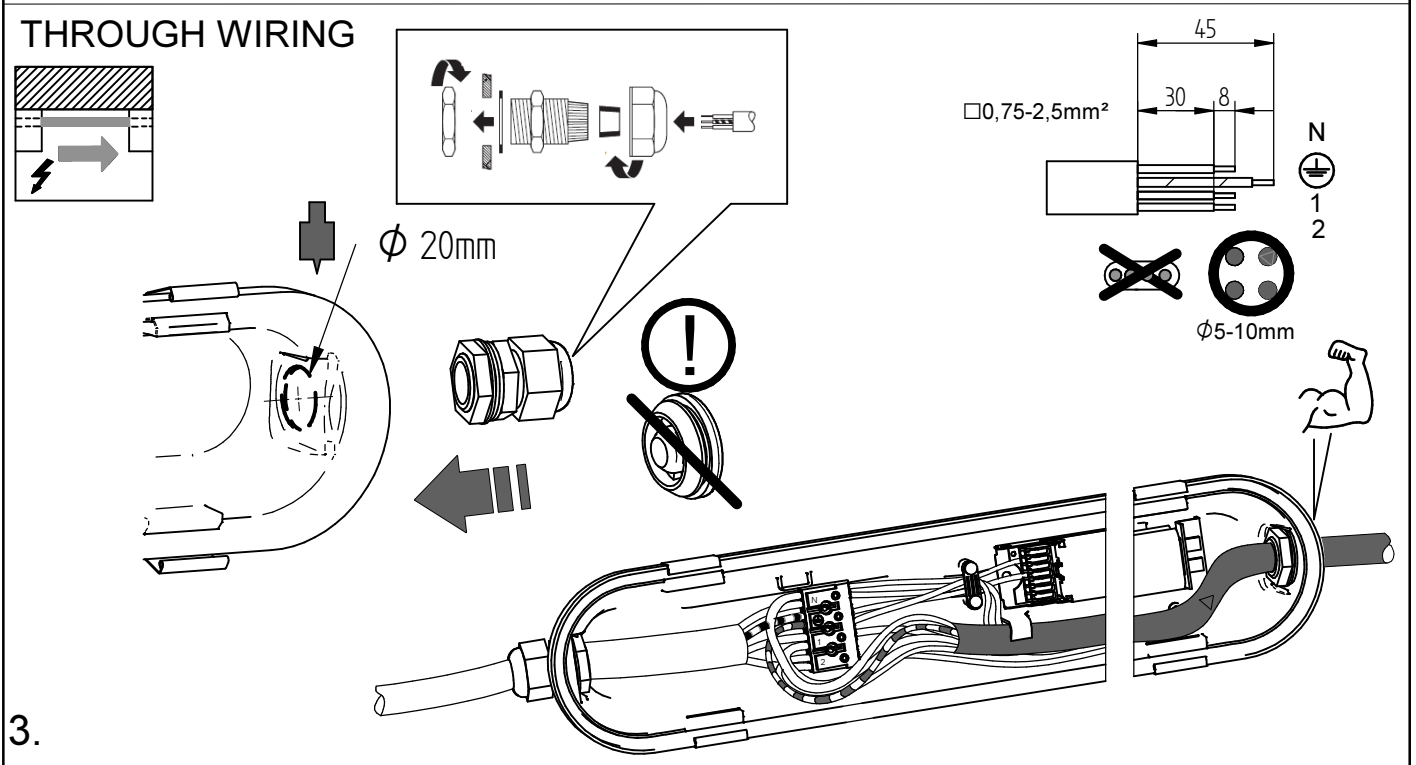

3.

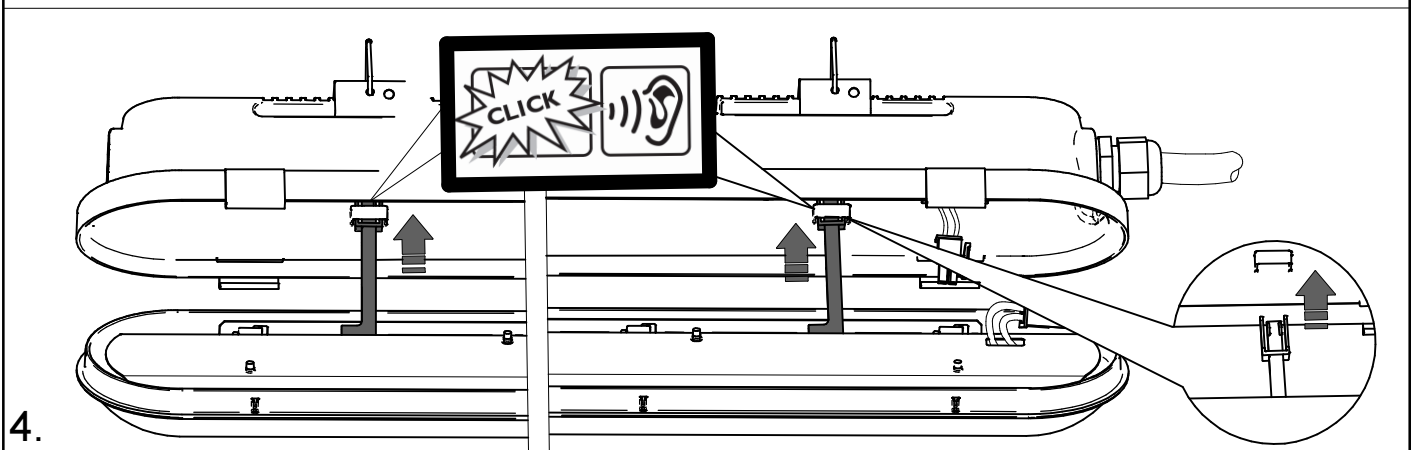

4.

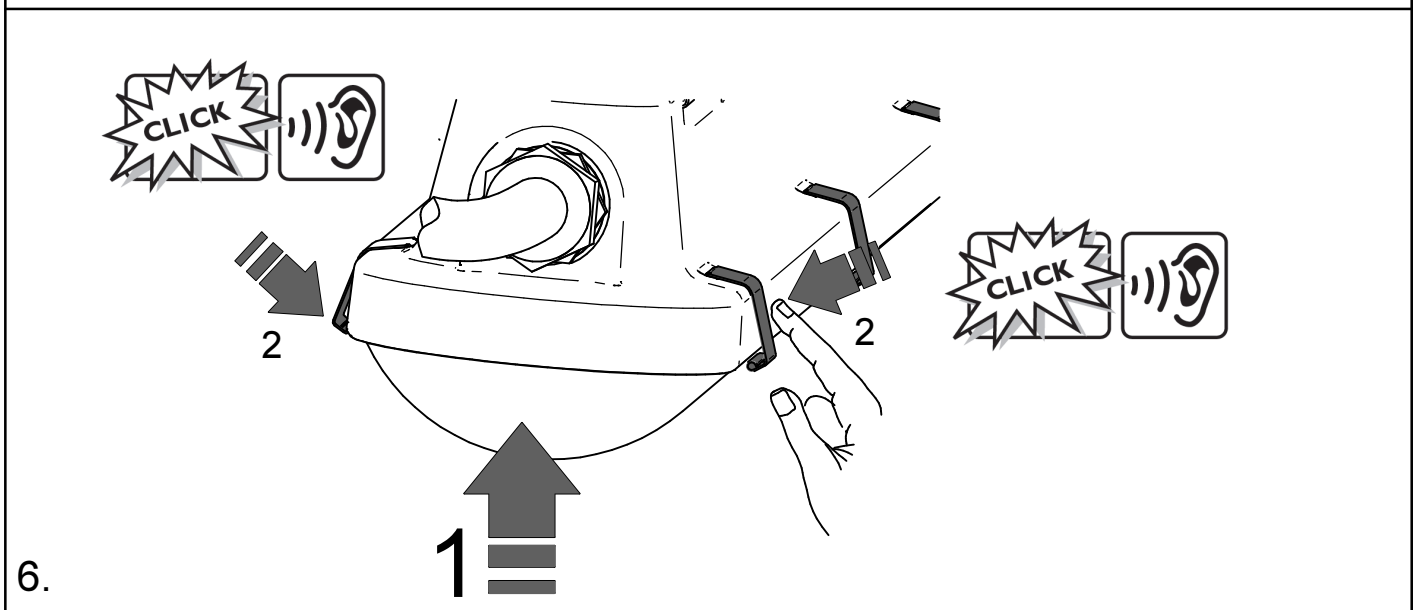
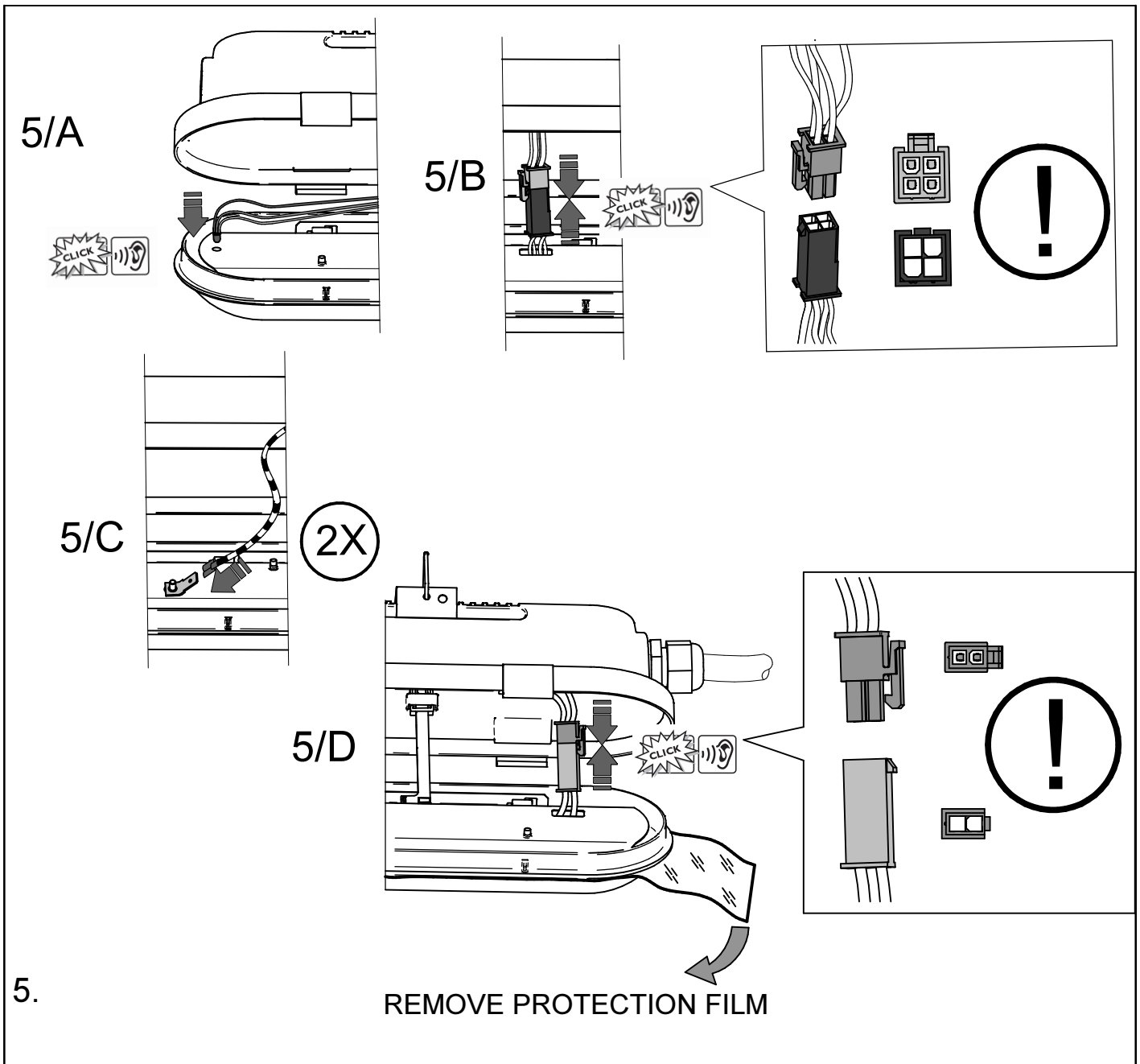

# SERVICE: (DRIVER / BATTERY REPLACEMENT)

The batteries have a life time expectancy of 4 years.

Light source (LED) is not replaceable.

## A) OPEN LUMINAIRE

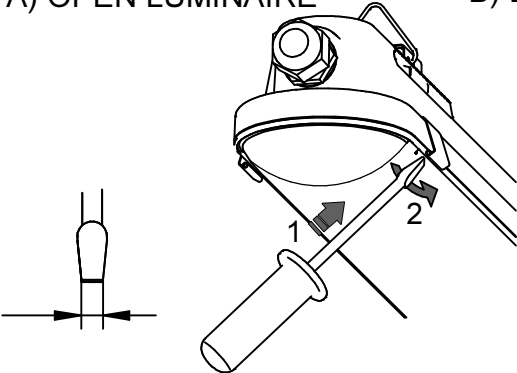

MAXIMAL SCREWDRIVER SIZE: 8MM

## B) DECOUPLE BATTERY WIRES

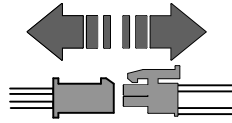

## C) UNTIGHT BATTERY SCREWS

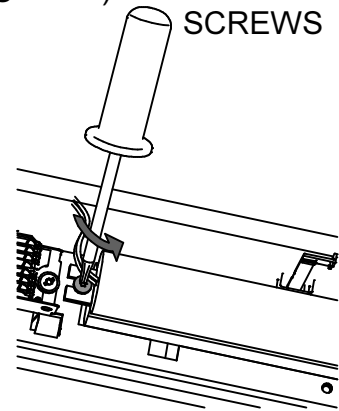

	LED22S	LED34S	LED40S	LED60S
$I_{peak}$ [A]	21	19	22	19
$T_{width}$ [ $\mu$ s]	255	275	235	275
	Max. Nr of products			
Drivers / MCB 16A type B [max.]	24	24	24	24
Drivers / MCB 10A type B [max.]	15	15	15	15
Drivers / MCB 16A type C [max.]	40	40	40	40
Drivers / MCB 10A type C [max.]	24	24	24	24

## LIGHT INTENSITY DISTRIBUTION CURVES EMERGENCY MODE

--- C 0-180 PLANE

--- C 90-270 PLANE

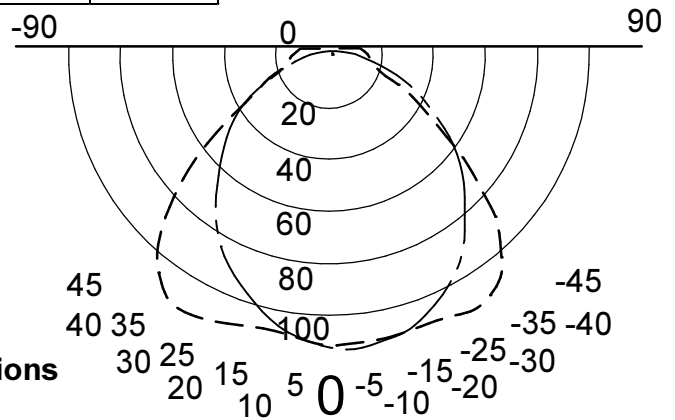
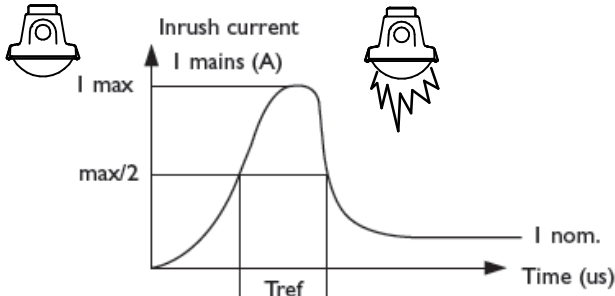

## Maintenance instructions

To assure the lighting quality of this unique LED lighting concept there are only a few instructions regarding the maintenance of this LED luminaire:

- \* Do not touch electronic components!  
Electronic components maybe under high voltage.
- \* Do not stare into LED light beam.
- \* The luminaire shall be installed by a qualified electrician and wired in accordance with the latest IEE electrical regulations or the national requirements.
- \* Above average concentraion of sulfur effects the useful lifetime of the product.  
E.g: Light color changes from white to blue. Typically in chicken & pig farms.
- \* Periodic tests should be performed according to EN 50172:2004, clause 7.2.3 and 7.2.4.  
Each month the driver is running in emergency mode for 30 seconds.  
Once a year a full discharge cycle of at least 1 hr or 3 hrs (depending on product installed) should be performed.

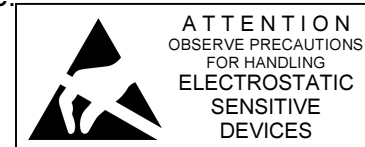

4443 160 03843

Version date : 31/01/2014

Data Subject to change without notice

Printed in EU

[www.philips.com/lighting](http://www.philips.com/lighting)

# PHILIPS